

SITE STATISTICS:

TOTAL GROSS AREA:	50,308 Ac.
NET AREA:	32,035 Ac.
EXISTING ZONING:	B-3
PROPOSED ZONING:	M-1
PROPOSED NUMBER OF LOTS:	6
PROPOSED BUILDING S.F.:	385,800 S.F.

M-1 ZONING REQUIREMENTS:

MINIMUM AREA:	40,000 S.F.
MINIMUM LOT WIDTH:	150'
MINIMUM LOT DEPTH:	200'
MINIMUM FRONT YARD:	35'
MINIMUM REAR YARD:	25'
MINIMUM SIDE YARD:	10'

- NOTES:**
1. TOPOGRAPHIC INFO SHOWN OBTAINED FROM HANOVER COUNTY GIS.
 2. SURROUNDING PARCEL INFO OBTAINED FROM HANOVER COUNTY GIS.
 3. SUBJECT PARCEL BOUNDARY REDRAWN FROM PLAT BY DOWNING SURVEYS, INC. DATED 3/20/96. PB.1200 PG.398
 4. NET AREA DEFINED AS GROSS AREA MINUS 100YR FLOODPLAIN AND RESOURCE PROTECTION AREA (RPA).

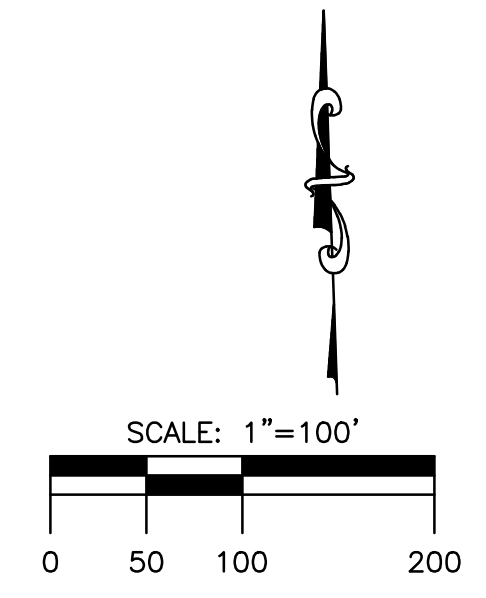

YOUNGBLOOD, TYLER & ASSOCIATES P.C.
 CONSULTING ENGINEERS, PLANNERS & SURVEYORS
 7309 HANOVER GREEN DRIVE, P.O. BOX 517, MECHANICSVILLE, VIRGINIA 23111
 PHONE: (804) 746-5285, FAX: (804) 730-7624, EMAIL: YOUNGBLOOD-TYLER@YOUNGBLOOD-TYLER.COM

GREEN TOP WASHINGTON HIGHWAY
 ELMONT DISTRICT HANOVER COUNTY, VIRGINIA

OVERALL PLAN

DATE: 02/15/2019

REVISIONS

NO.	DATE	DESCRIPTION

DESIGNED BY: WAB
 DRAWN BY: JMD
 CHECKED BY: WAB

J. N.: 497-01-001
 CAD FILE: 497-01-001-GREENTOP